



PORTABLE ALUMINUM DAVIT CRANE

COMMANDER[®] AL



COMMANDER[®] AL

PORTABLE ALUMINUM DAVIT CRANE



LIFTING POTENTIAL

Mobility and Enhanced Versatility

Introducing the 5AT1 and 5AT2 Commander AL portable aluminum davit crane, Thern's cutting-edge advancement in portable lifting solutions, now crafted from lightweight aluminum. With a remarkable lifting capacity of up to 1,200 pounds, this innovative crane offers unprecedented portability and adaptability to diverse work environments. Featuring a towering maximum hook height of 85 inches, it effortlessly navigates obstacles and elevates heavy loads with precision and ease. The seamless integration of a 360-degree lifting, lowering, and rotating mechanism ensures seamless maneuverability for swift and efficient operations. When incorporating an optional rotation bearing and a 12-position lock system, this crane streamlines movement and enhances load stability during unloading processes. Swift disassembly and reassembly facilitated by quick-release hardware and pins optimize transportability, making it an indispensable asset across various industries including water/wastewater, manufacturing, marine, construction, and oil and gas sectors.

Enhanced Portability

- Effortlessly disassembles and reassembles utilizing quick-release hardware and pins, facilitating rapid transport to storage or alternate job sites without additional tools.
- Seamlessly relocate your crane to another site while retaining the wire rope connected to the load through the convenient quick-disconnect feature. Simply insert the swaged-ball end of the wire rope into the keyhole slot on the gusset of the pedestal base or into an optional wire rope keeper or cable spool.
- Ergonomically designed with no individual components exceeding 50 lbs in weight, ensuring ease of handling during setup and breakdown.

Versatile Configurations

- Boasting an array of base mounting options such as pedestal, flush, wall-mount, and wheel-base configurations, the crane effortlessly adapts to diverse lifting requirements with precision and ease.
- Standard quick-mount winch bracket requires minimal tools for installation and is compatible with various Thern winches, ensuring seamless integration and operational efficiency.
- For enhanced flexibility, an optional base extension is available, offering added height without compromising the crane's load rating. Particularly beneficial for wall- or flush-mount installations, where increased crane height is necessary for obstacle clearance or specific operational demands, providing an impressive additional 15 inches (38cm) of elevation.



Product Shown:
5AT2-M1

STANDARD CONFIGURATIONS

Series	IMPERIAL/METRIC	
	Description	Up To Capacity
5AT1-M1	Powder-coat crane with M4022PB spur gear hand winch	650 lbs / 300 kg
5AT1-M2	Powder-coat crane with 4WM2 worm gear hand winch	650 lbs / 300 kg
5AT1-M3	Powder-coat crane with M4042PBSS spur gear hand winch	650 lbs / 300 kg
5AT1-E2	Powder-coat crane with 4WP2 electric winch	650 lbs / 300 kg
5AT1-E4	Powder-coat crane with 4777 electric winch	650 lbs / 300 kg

Series	IMPERIAL/METRIC	
	Description	Up To Capacity
5AT2-M1	Powder-coat crane with M4312PB spur gear hand winch	1,200 lbs / 540 kg
5AT2-M2	Powder-coat crane with 4WM2 worm gear hand winch	1,200 lbs / 540 kg
5AT2-M3	Powder-coat crane with M4312PBSS spur gear hand winch	1,200 lbs / 540 kg
5AT2-E2	Powder-coat crane with 4WP2 electric winch	1,200 lbs / 540 kg
5AT2-E4	Powder-coat crane with 4777 electric winch	1,200 lbs / 540 kg

Robust Build & Impeccable Finish

- Crafted from rugged, welded 6061 aluminum pipe and tubing, ensures minimal deflection.
- Shielded against corrosion by a resilient powder-coated frame, mast cap, and stainless-steel fasteners, fortifies the crane against the elements and extends its operational lifespan. Additionally, an epoxy finish option is available for environments prone to corrosion, further enhancing its longevity in harsh conditions.

Refer to technical pages for detailed performance information.

NOTICE: These products are not for lifting people or things over people.

TECHNICAL DRAWINGS & SPECIFICATIONS
COMMANDER[®] AL
 PORTABLE ALUMINUM DAVIT CRANE

5AT1 CONFIGURATIONS

Model	Description	Approx. Ship Wt.	
		(lb)	(kg)
Popular Configurations			
5AT1-M1	Up to 650 lb capacity with M4022PB super gear hand winch – powder-coat crane	70	32
5AT1-M2	Up to 650 lb capacity with 4WM2 worm gear hand winch - powder-coat crane	91	42
5AT1-M3	Up to 650 lb capacity with M4042PBSS spur gear hand winch - powder-coat crane	78	36
5AT1-E2	Up to 650 lb capacity with 4WP2 electric winch - powder-coat crane	127	58
5AT1-E2L	Up to 650 lb capacity with 4WP2 limit switch ready electric winch - powder-coat crane	127	58
5AT1-E4	Up to 650 lb capacity with 4777 electric winch - powder-coat crane	149	68
5AT1-E4L	Up to 650 lb capacity with 4777 limit switch ready electric winch - powder-coat crane	149	68
5AT1-E4DC	Up to 650 lb capacity with 4777, 12V DC electric winch - powder-coat crane	173	79
5AT1-E4DCL	Up to 650 lb capacity with 4777, limit switch ready,12V DC electric winch - powder-coat crane	173	79
Crane Only			
5AT1	Up to 650 lb capacity – base model- powder-coat finish	53	24.1
Winch Only			
M1	M4022PB super gear hand winch only – clear zinc coating	17	8
M2	4WM2-K worm gear hand winch only – powder-coat	38	17
M3	M4042PBSS spur gear hand winch only – stainless steel	24	11
E2	4WP2-K electric winch only – 115/1/60 VAC with 6 ft pendant control - enamel	73	33
E2L	4WP2-K limit switch ready electric winch only – 115/1/60 VAC with 6 ft pendant control - enamel	73	33
E4	4777-K electric winch only – 115/1/60 VAC with 6 ft pendant control - enamel	95	43
E4L	4777-K limit switch ready electric winch only – 115/1/60 VAC with 6 ft pendant control - enamel	95	43
E4DC	4777DC-K electric winch -12 Volt DC with 10ft pendant control – enamel	119	54
E4DCL	4777DC-K limit switch ready electric winch -12 Volt DC with 10ft pendant control – enamel	119	54

Commander 5AT1 Winch Configurations



5AT1 & 5AT2 Bases and Wire Rope

Independent Bases—sold separately

Pedestal, socket, or wall-mount style.

Wheel base for floor crane operation. Base legs adjust in length and width. See Model 5BR10.

IMPORTANT: Base installation is the customer's responsibility. Thern recommends consulting a civil engineer or other qualified professional. Contact Thern for installation guidelines.

Finish	Pedestal (Steel)		Flush (Steel Only)		Wall (Steel Only)		Wheel (Steel Only)		Extension (Steel Only)	
	5AT1	5AT2	5AT1	5AT2	5AT1	5AT2	5AT1	5AT2	5AT1	5AT2
Powder Coat Paint	5BP10	5BP20	5BF10	5BF20	5BW10	5BW20	5BR10	5BR20	5BE10-15	5BE20-15
Galvanized	5BP10G	5BP20G	5BF10G	5BF10G	5BW10G	5BW20G	—	—	5BE10-15G	5BE20-15G
304 Stainless Steel	5BP10S	5BP20S	5BF10S	5BF20S	5BW10S	5BW20S	—	—	5BE10-15S	5BE20-15S
316 Stainless Steel	5BP10S316	5BP20S316	5BF10S316	5BF20S316	5BW10S316	5BW20S316	—	—	5BE10-15S316	5BE20-15S316
Epoxy Paint	5BP10X	5BP20X	5BF10X	5BF20X	5BW10X	5BW20X	5BR10X	5BR20X	5BE10-15X	5BE20-15X
Approximate Ship Weight	52 lbs (24 kg)	66lbs (30 kg)	44 lbs (20 kg)	57 lbs (26 kg)	48 lbs (22 kg)	64 lbs (30 kg)	285 lbs (130 kg)	375 lbs (171 kg)	33 lbs (15 kg)	53 lbs (25 kg)

Wire Rope Assemblies—sold separately

Galvanized or stainless steel wire rope assemblies with swaged-ball fitting to work with the quick-disconnect anchor on the winch. 316 stainless also available. Please contact Thern.

Wire Rope Length	Galvanized Aircraft Cable		304 Stainless Steel Wire Rope	
	3/16" Dia. (4.8 mm)	1/4" Dia. (6.4 mm)	3/16" Dia. (4.8 mm)	1/4" Dia. (6.4 mm)
(ft) (m)	Model No.	Model No.	Model No.	Model No.
20 6.0	WA19-20NS	WA25-20NS	WS19-20NS	WS25-20NS
28 8.5	WA19-28NS	WA25-28NS	WS19-28NS	WS25-28NS
36 10.9	WA19-36NS	WA25-36NS	WS19-36NS	WS25-36NS
45 13.7	WA19-45NS	WA25-45NS	WS19-45NS	WS25-45NS
60 18.2	WA19-60NS	WA25-60NS	WS19-60NS	WS25-60NS
75 22.8	WA19-75NS	WA25-75NS	WS19-75NS	WS25-75NS
90 27.4	WA19-90NS	—	WS19-90NS	—



COMMANDER® AL 5AT1 PERFORMANCE RATINGS

5AT1 Series Lift Below Floor²

Lift Below ¹ Floor				Wire Rope Diameter		Wire Rope ³ Length		Winch Configurations				
Minimum (C4)		Maximum (C1)						M1	M2	M3	E2	E4
(ft)	(m)	(ft)	(m)	(in)	(mm)	(ft)	(m)					
2	0.6	7	2.1	3/16	5	20	6.0	x	-	x	-	x
10	3.0	15	4.5	3/16	5	28	8.5	x	-	x	-	x
18	5.4	23	7.0	3/16	5	36	10.9	x	-	x	-	x
27	8.2	32	9.7	3/16	5	45	13.7	x	-	x	-	x
42	12.8	47	14.3	3/16	5	60	18.2	x	-	x	-	x
57	17.3	62	18.8	3/16	5	75	22.8	-	-	x	-	x
72	21.9	77	23.4	3/16	5	90	27.4	-	-	x	-	x
2	0.6	7	2.1	1/4	6	20	6.0	-	x	x	x	x
10	3.0	15	4.5	1/4	6	28	8.5	-	x	x	x	x
18	5.4	23	7.0	1/4	6	36	10.9	-	x	x	x	x
27	8.2	32	9.7	1/4	6	45	13.7	-	x	x	x	x
42	12.8	47	14.3	1/4	6	60	18.2	-	x	x	x	x
57	17.3	62	18.8	1/4	6	75	22.8	-	x	-	x	x
72	21.9	77	23.4	1/4	6	90	27.4	-	-	-	-	x

Commander 5AT1 Hook Height and Reach²

Boom Position	Load Rating		Hook Reach		Hook Height	
	(lb)	(kg)	(in)	(mm)	(in)	(mm)
BLUE RANGE						
A-1	550	250	36	914	42	1066
A-2	425	190	46	1168	42	1066
A-3	350	160	56	1422	42	1066
A-4	300	135	66	1676	42	1066
GREEN RANGE						
B-1	650	300	29	736	56	1422
B-2	525	235	38	965	60	1524
B-3	425	190	47	1193	65	1651
B-4	350	160	56	1422	69	1752
C-1	650	300	22	558	64	1625
C-2	525	235	29	736	71	1803
C-3	425	190	36	914	78	1981
C-4	350	160	43	1092	85	2159

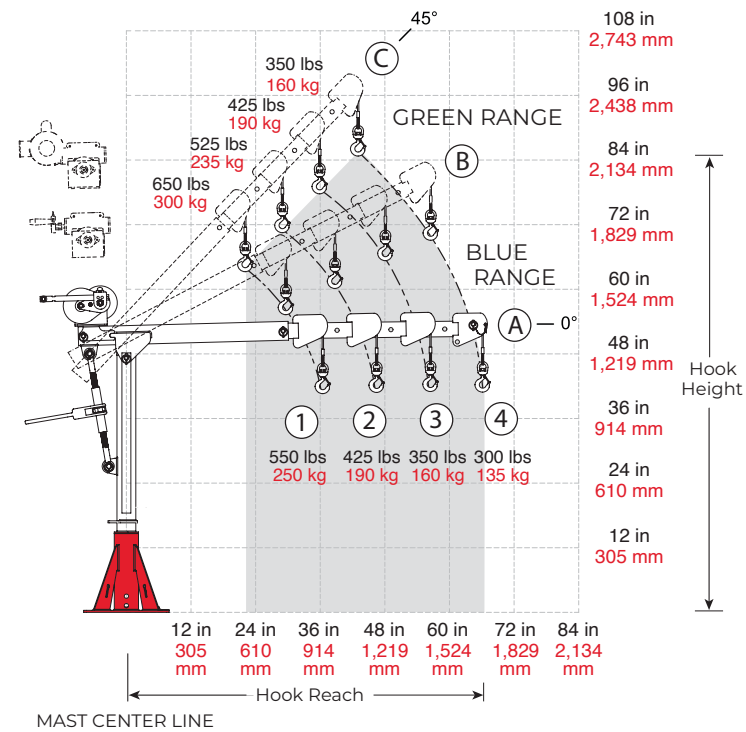

- Lift below floor level varies depending on boom position and base configuration. For longer lifts, including use with two-part lines kits, please contact factory.
- Performance Characteristics are for standard products referred to in this manual. Non-standard products may vary from the original design. Contact Thern, Inc. for this information.
- Wire rope assemblies include a hook and a swaged ball fitting to work with quick disconnect anchor on the winch. 316SS wire rope is available. Please contact the factory.

IMPORTANT:

It is the owner or operator's responsibility to determine the suitability of the equipment to its intended use. Study all applicable codes, manuals and regulations. Be sure to read the Owner's Manual supplied with the equipment before operating it.

COMMANDER® AL 5AT1 PERFORMANCE RATINGS

Commander® AL 5AT1 with Pedestal Base Reach & Height Above Floor¹

Boom Position	Hook Reach		Hook Height	
	(in)	(mm)	(in)	(mm)
A-1	36	914	42	1,066
A-2	46	1,168	42	1,066
A-3	56	1,422	42	1,066
A-4	66	1,676	42	1,066
B-1	29	736	56	1,422
B-2	38	965	60	1,524
B-3	47	1,193	65	1,651
B-4	56	1,422	69	1,752
C-1	22	558	64	1,625
C-2	29	736	71	1,803
C-3	36	914	78	1,981
C-4	43	1,092	85	2,159

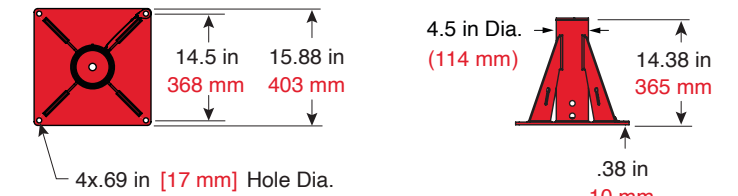

Commander® AL 5AT1 Pedestal Base

5BP10 5BP10S 5BP10X
5BP10G 5BP10S316 5ABP1

¹Performance Characteristics are for standard products. Non-standard products may vary from the original design. Contact Thern, Inc. for this information.

Dimensions are for reference only and subject to change without notice.

Commander® AL 5AT1 Performance Ratings²

Boom Position	Load Rating	
	(lb)	(kg)
BLUE RANGE		
A-1	550	250
A-2	425	190
A-3	350	160
A-4	300	135
GREEN RANGE		
B-1	650	300
B-2	525	235
B-3	425	190
B-4	350	160
C-1	650	300
C-2	525	235
C-3	425	190
C-4	350	160

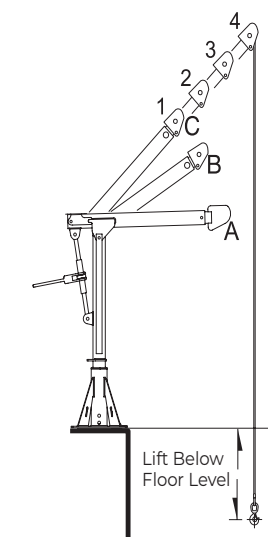
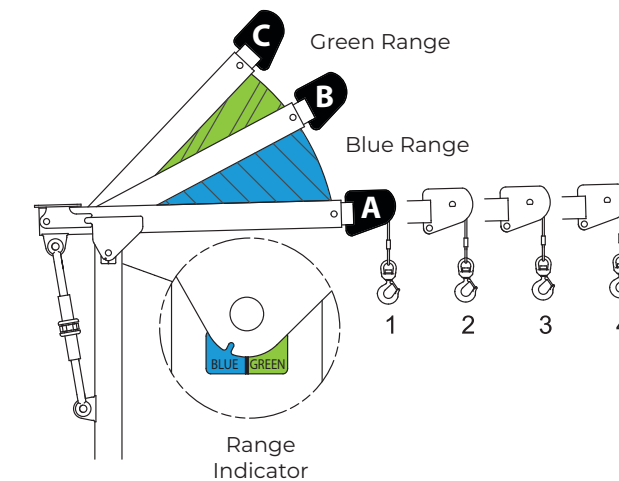

COMMANDER® AL 5AT1 PERFORMANCE RATINGS CONTINUED

Commander® AL 5AT1 with Flush- or Wall-Mount Base Reach & Height Above Floor¹

Boom Position	Hook Reach		Hook Height	
	(in)	(mm)	(in)	(mm)
A-1	36	914	28	711
A-2	46	1,168	28	711
A-3	56	1,422	28	711
A-4	66	1,676	28	711
B-1	29	736	42	1,066
B-2	38	965	46	1,168
B-3	47	1,193	51	1,295
B-4	56	1,422	55	1,397
C-1	22	558	50	1,270
C-2	29	736	57	1,447
C-3	36	914	64	1,625
C-4	43	1,092	71	1,803

¹Performance Characteristics are for standard products. Non-standard products may vary from the original design. Contact Thern, Inc. for this information.

Dimensions are for reference only and subject to change without notice.

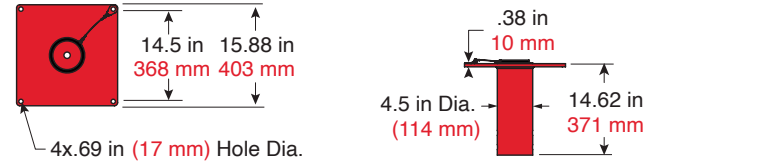

Commander® AL 5AT1 Flush-Mount Base

5BF10 5BF10G 5BF10S
5BF10S316 5BF10X

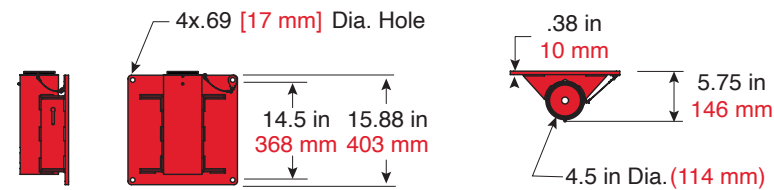

Commander® AL 5AT1 Wall-Mount Base

5BW10 5BW10G 5BW10S
5BW10S316 5BW10X

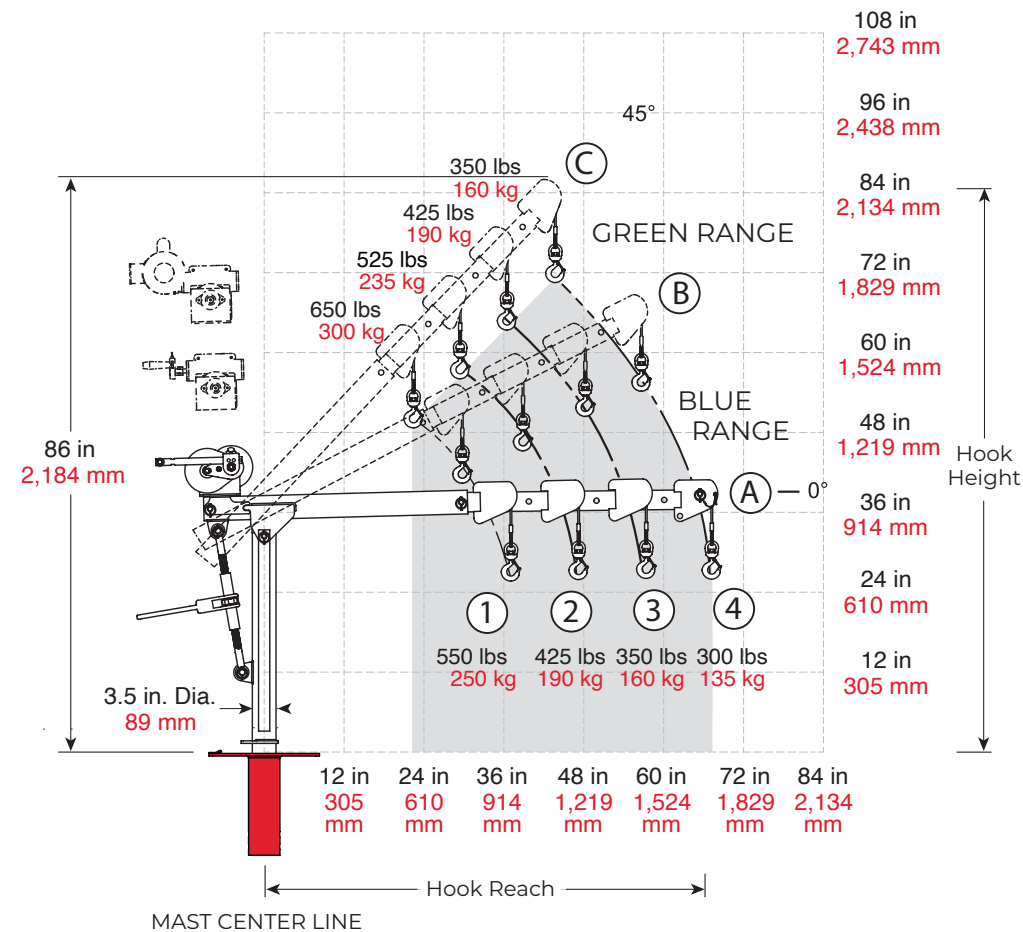

COMMANDER® AL 5AT1 PERFORMANCE RATINGS CONTINUED

Commander® AL 5AT1 on Wheel Base Reach & Height Above Floor

Boom Position	Hook Reach		Hook Height	
	(in)	(mm)	(in)	(mm)
A-1	36	914	48	1,219
A-2	46	1,168	48	1,219
A-3	56	1,422	48	1,219
A-4	66	1,676	48	1,219
B-1	29	736	62	1,574
B-2	38	965	66	1,676
B-3	47	1,193	71	1,803
B-4	56	1,422	75	1,905
C-1	22	558	70	1,778
C-2	29	736	77	1,955
C-3	36	914	84	2,133
C-4	43	1,092	91	2,311

Dimensions are for reference only and subject to change without notice.

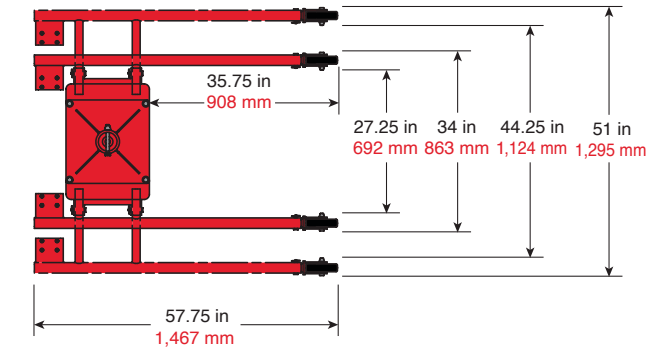

Commander® AL 5AT1 Wheel Base

5BR10 5BR10X

Commander® AL 5AT1 Wheel Base Load Ratings

Boom Position	Leg Pos. 1		Leg Pos. 2		Leg Pos. 3		Leg Pos. 4	
	(lb)	(kg)	(lb)	(kg)	(lb)	(kg)	(lb)	(kg)
A-1	SEE LOAD RATINGS ON CRANE							
A-2	SEE LOAD RATINGS ON CRANE							
A-3	DO NOT USE							
A-4	DO NOT USE							
B-1	SEE LOAD RATINGS ON CRANE							
B-2	SEE LOAD RATINGS ON CRANE							
B-3	SEE LOAD RATINGS ON CRANE							
B-4	DO NOT USE							

Dimensions are for reference only and subject to change without notice.

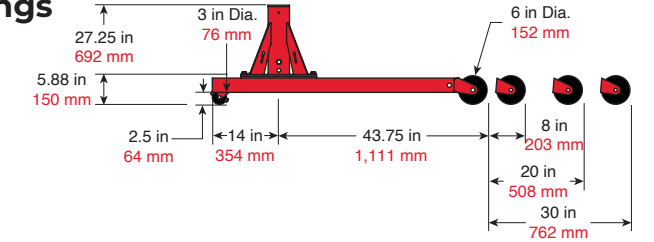

Commander® AL 5AT1 on Wheel Base



IMPORTANT: Crane DOES NOT rotate when assembled in 5BR10 wheel base.

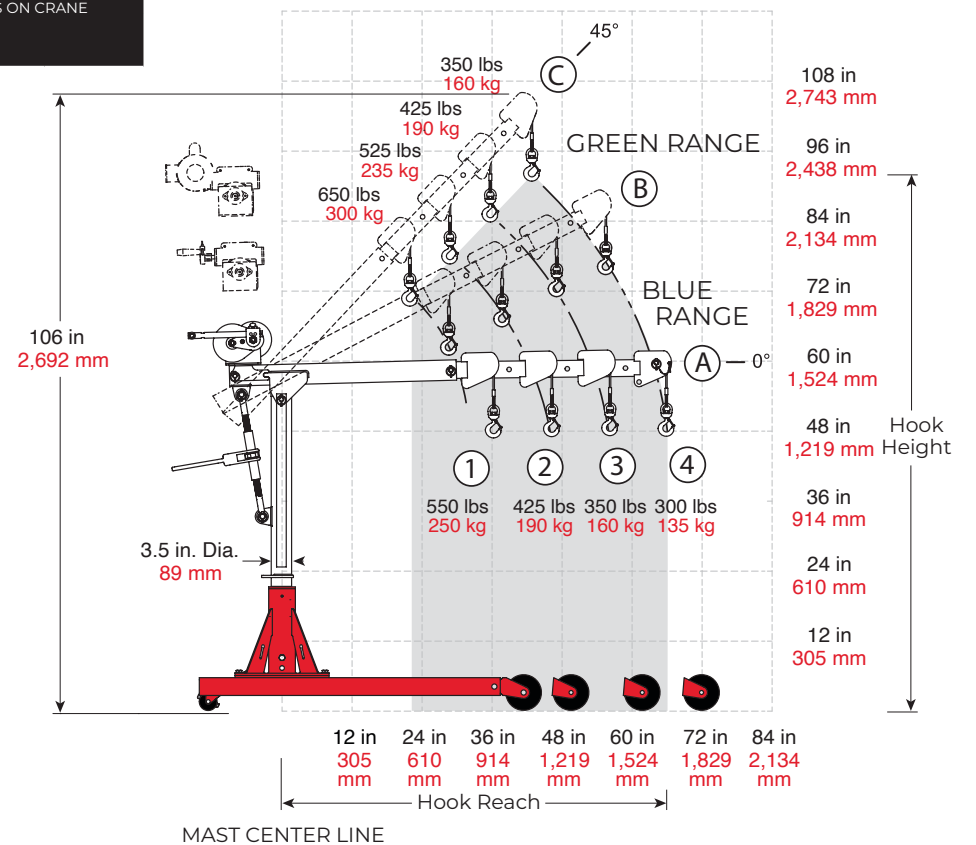

5AT2 CONFIGURATIONS

Model	Description	Approx. Ship Wt.	
		(lb)	(kg)
Popular Configurations			
5AT2-M1	Up to 1200 lb capacity with M4312PB spur gear hand winch – powder-coat crane	109	50
5AT2-M2	Up to 1200 lb capacity with 4WM2 worm gear hand winch - powder-coat crane	120	55
5AT2-M3	Up to 1200 lb capacity with M4312PBSS spur gear hand winch – powder-coat crane	109	50
5AT2-E2	Up to 1200 lb capacity with 4WP2 electric winch - powder-coat crane	154	70
5AT2-E2L	Up to 1200 lb capacity with 4WP2 limit switch ready electric winch - powder-coat crane	154	70
5AT2-E2T	Up to 1200 lb capacity with 4WP2 electric winch with additional drum capacity - powder-coat crane	164	75
5AT2-E2TL	Up to 1200 lb capacity with 4WP2 limit switch ready electric winch with additional drum capacity- powder-coat crane	164	75
5AT2-E4	Up to 1200 lb capacity with 4777 electric winch - powder-coat crane	176	80
5AT2-E4L	Up to 1200 lb capacity with 4777 limit switch ready electric winch - powder-coat crane	176	80
5AT2-E4DC	4777DC electric winch -12 Volt DC with 10ft pendant control – enamel	200	91
5AT2-E4DCL	4777DC limit switch ready electric winch -12 Volt DC with 10ft pendant control – enamel	200	91
Crane Only			
5AT2	Up to 1200 lb capacity – base model- powder-coat finish	81	38
Winch Only			
M1	M4312PB spur gear hand winch – clear zinc coating	29	13
M2	4WM2-K worm gear hand winch only – powder-coat	39	18
M3	M4312PBSS spur gear hand winch – stainless steel	29	13
E2	4WP2-K electric winch only – 115/1/60 VAC with 6 ft pendant control - enamel	74	34
E2L	4WP2-K limit switch ready electric winch only – 115/1/60 VAC with 6 ft pendant control - enamel	74	34
E2T	4WP2-K electric winch with additional drum capacity only - 115/1/60 VAC with 6 ft pendant control - enamel	80	36
E2TL	4WP2 -K limit switch ready electric winch with additional drum capacity only - 115/1/60 VAC with 6 ft pendant control - enamel	80	36
E4	4777-K electric winch only – 115/1/60 VAC with 6 ft pendant control - enamel	96	44
E4L	4777-K limit switch ready electric winch only – 115/1/60 VAC with 6 ft pendant control - enamel	96	44
E4DC	4777DC-K electric winch -12 Volt DC with 10ft pendant control – enamel	120	55
E4DCL	4777DC-K limit switch ready electric winch -12 Volt DC with 10ft pendant control – enamel	120	55

Commander 5AT2 Winch Configurations *See bases and wire rope section for available options.*



COMMANDER® AL 5AT2 PERFORMANCE RATINGS

5AT2 Series Lift Below Floor²

Lift Below ¹ Floor				Wire Rope Diameter		Wire Rope ³ Length		Winch Configurations					
Minimum (C4)		Maximum (C1)						M1	M2	M3	E2	E2T	E4
(ft)	(m)	(ft)	(m)	(in)	(mm)	(ft)	(m)						
2	0.6	7	2.1	3/16	5	20	6.0	x	-	x	-	x	x
10	3.0	15	4.5	3/16	5	28	8.5	x	-	x	-	x	x
18	5.4	23	7.0	3/16	5	36	10.9	x	-	x	-	x	x
27	8.2	32	9.7	3/16	5	45	13.7	x	-	x	-	x	x
42	12.8	47	14.3	3/16	5	60	18.2	x	-	x	-	x	x
57	17.3	62	18.8	3/16	5	75	22.8	-	-	x	-	x	x
72	21.9	77	23.4	3/16	5	90	27.4	-	-	x	-	x	x
102	31.0	107	32.6	3/16	5	120	36.5	-	-	-	-	x	x
132	40.2	137	41.7	3/16	5	150	45.7	-	-	-	-	x	x
2	0.6	7	2.1	1/4	6	20	6.0	-	x	x	x	x	x
10	3.0	15	4.5	1/4	6	28	8.5	-	x	x	x	x	x
18	5.4	23	7.0	1/4	6	36	10.9	-	x	x	x	x	x
27	8.2	32	9.7	1/4	6	45	13.7	-	x	x	x	x	x
42	12.8	47	14.3	1/4	6	60	18.2	-	x	x	x	x	x
57	17.3	62	18.8	1/4	6	75	22.8	-	x	-	x	x	x
72	21.9	77	23.4	1/4	6	90	27.4	-	-	-	-	x	x
102	31.0	107	32.6	1/4	6	120	36.5	-	-	-	-	x	-
132	40.2	137	41.7	1/4	6	150	45.7	-	-	-	-	x	-

Commander 5AT2 Hook Height and Reach²

	Boom Position	1st Layer Load Rating*		Hook Reach		Hook Height	
		(lb)	(kg)	(in)	(mm)	(in)	(mm)
BLUE RANGE	A-1	1000	455	36	914	42	1066
	A-2	800	360	46	1168	42	1066
	A-3	650	295	56	1422	42	1066
	A-4	550	250	66	1676	42	1066
GREEN RANGE	B-1	1200	540	29	736	56	1422
	B-2	950	430	38	965	60	1524
	B-3	750	340	47	1193	65	1651
	B-4	650	295	56	1422	69	1752
GREEN RANGE	C-1	1200	540	22	558	64	1625
	C-2	950	430	29	736	71	1803
	C-3	750	340	36	914	78	1981
	C-4	650	295	43	1092	85	2159

* Crane maximum load rating: load rating may decrease as layers of rope wind into the winch drum. Refer to winch load rating

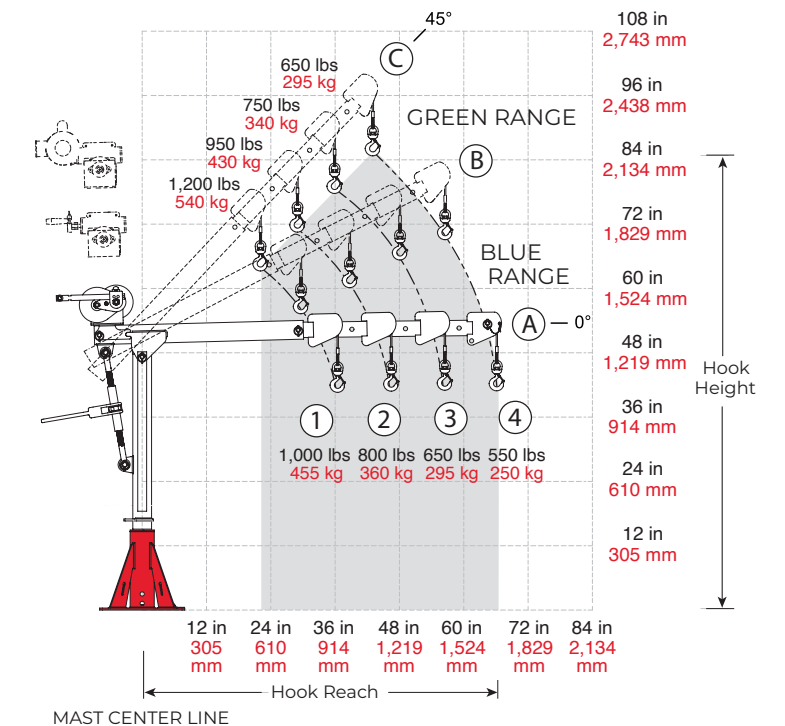

IMPORTANT:

It is the owner or operator's responsibility to determine the suitability of the equipment to its intended use. Study all applicable codes, manuals and regulations. Be sure to read the Owner's Manual supplied with the equipment before operating it.

¹ Lift below floor level varies depending on boom position and base configuration. For longer lifts, including use with two-part lines kits, please contact factory.

² Performance Characteristics are for standard products referred to in this manual. Non-standard products may vary from the original design. Contact Thern, Inc. for this information.

³ Wire rope assemblies include a hook and a swaged ball fitting to work with quick disconnect anchor on the winch.

COMMANDER® AL 5AT2 PERFORMANCE RATINGS CONTINUED

Commander® AL 5AT2 with Pedestal Base Reach & Height Above Floor¹

Boom Position	Hook Reach		Hook Height	
	(in)	(mm)	(in)	(mm)
A-1	36	914	42	1,066
A-2	46	1,168	42	1,066
A-3	56	1,422	42	1,066
A-4	66	1,676	42	1,066
B-1	29	736	56	1,422
B-2	38	965	60	1,524
B-3	47	1,193	65	1,651
B-4	56	1,422	69	1,752
C-1	22	558	64	1,625
C-2	29	736	71	1,803
C-3	36	914	78	1,981
C-4	43	1,092	85	2,159

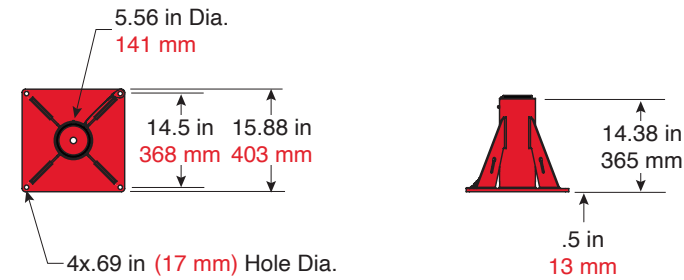

Commander® AL 5AT2 Pedestal Base

5BP20 5BP20S 5BP20X
5BP20G 5BP20S316 5ABP2

¹Performance Characteristics are for standard products. Non-standard products may vary from the original design. Contact Thern, Inc. for this information.

Dimensions are for reference only and subject to change without notice.

Commander® AL 5AT2 Performance Ratings²

Boom Position	Load Rating	
	(lb)	(kg)
A-1	1,000	455
A-2	800	360
A-3	650	295
A-4	550	250
B-1	1,200	540
B-2	950	430
B-3	750	340
B-4	650	295
C-1	1,200	540
C-2	950	430
C-3	750	340
C-4	650	295

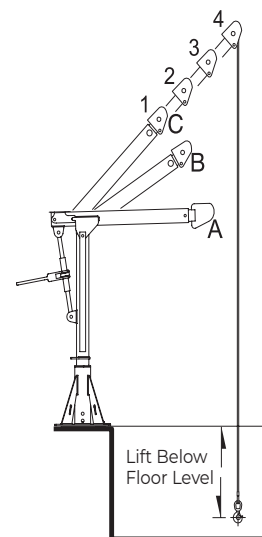
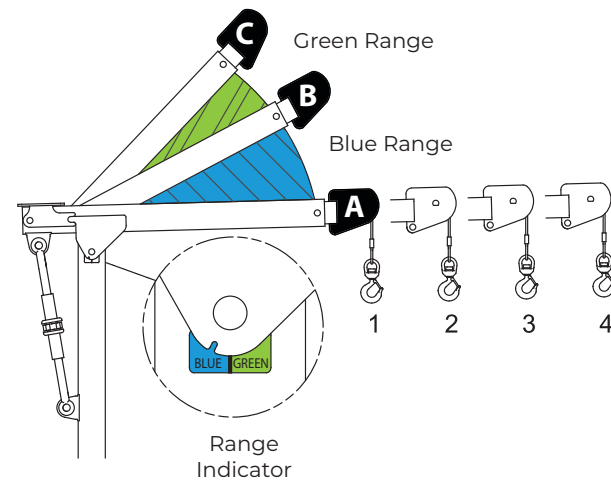

COMMANDER® AL 5AT2 PERFORMANCE RATINGS CONTINUED

Commander® AL 5AT2 with Flush- or Wall-Mount Base Reach & Height Above Floor¹

Boom Position	Hook Reach		Hook Height	
	(in)	(mm)	(in)	(mm)
A-1	36	914	28	711
A-2	46	1,168	28	711
A-3	56	1,422	28	711
A-4	66	1,676	28	711
B-1	29	736	42	1,066
B-2	38	965	46	1,168
B-3	47	1,193	51	1,295
B-4	56	1,422	55	1,397
C-1	22	558	50	1,270
C-2	29	736	57	1,447
C-3	36	914	64	1,625
C-4	43	1,092	71	1,803

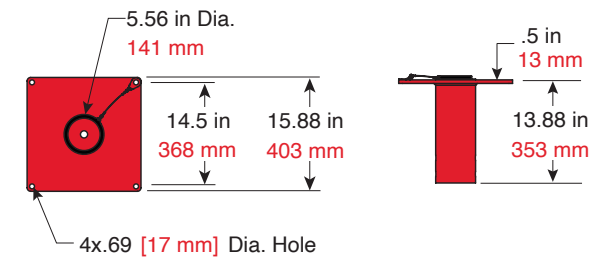

Commander® AL 5AT2 Flush-Mount Base

5BF20 5BF20G 5BF20S
5BF20S316 5BF20X

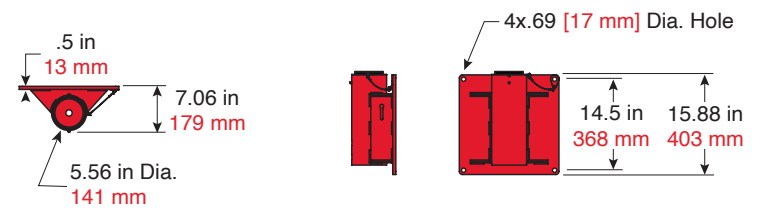

Commander® AL 5AT2 Wall-Mount Base

5BW20 5BW20G 5BW20S
5BW20S316 5BW20X

¹Performance Characteristics are for standard products. Non-standard products may vary from the original design. Contact Thern, Inc. for this information.
Dimensions are for reference only and subject to change without notice.

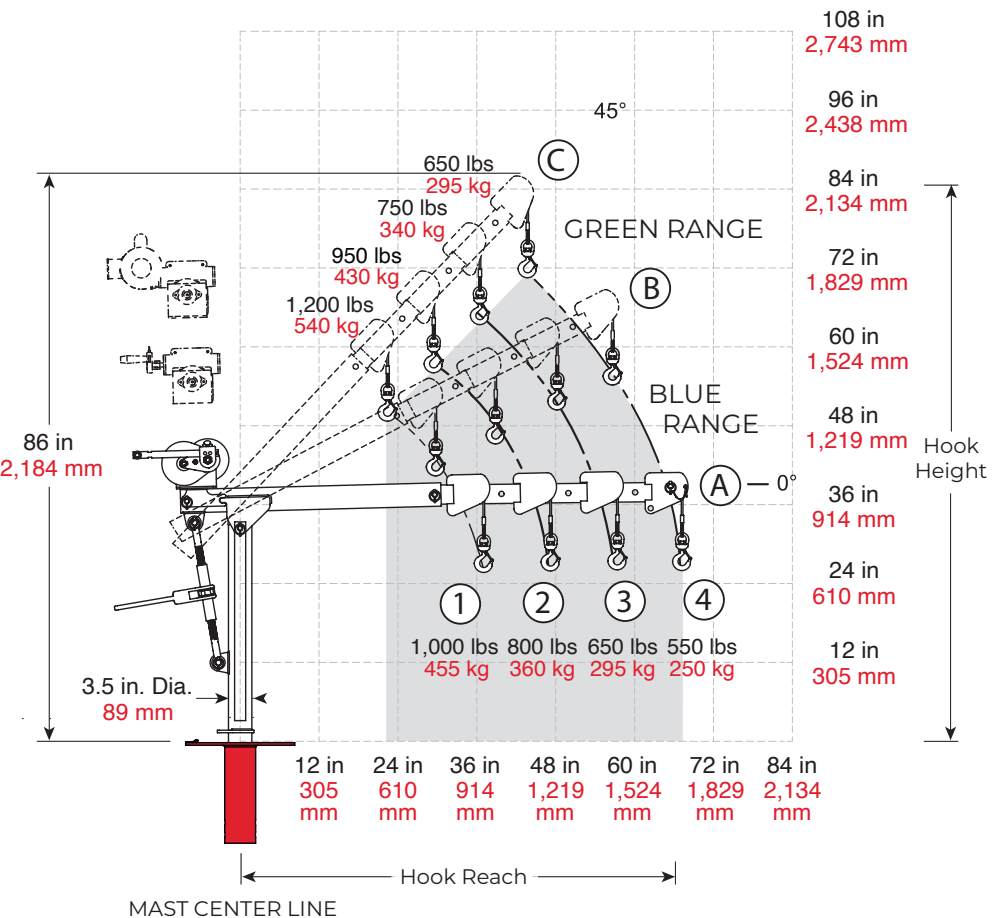

COMMANDER® AL 5AT2 PERFORMANCE RATINGS

Commander® AL 5AT2 on Wheel Base Reach & Height Above Floor

Boom Position	Hook Reach		Hook Height	
	(in)	(mm)	(in)	(mm)
A-1	36	914	48	1,219
A-2	46	1,168	48	1,219
A-3	56	1,422	48	1,219
A-4	66	1,676	48	1,219
B-1	29	736	62	1,574
B-2	38	965	66	1,676
B-3	47	1,193	71	1,803
B-4	56	1,422	75	1,905
C-1	22	558	70	1,778
C-2	29	736	77	1,955
C-3	36	914	84	2,133
C-4	43	1,092	91	2,311

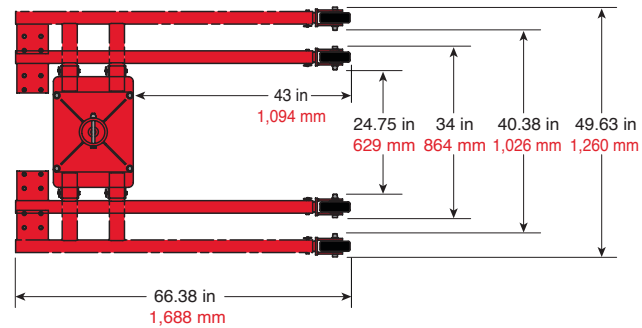

Commander 5AT2 Wheel Base
5BR20 5BR20X

Dimensions are for reference only and subject to change without notice.

Commander® AL 5AT2 Wheel Base Load Ratings

Boom Position	Leg Pos. 1		Leg Pos. 2		Leg Pos. 3		Leg Pos. 4	
	(lb)	(kg)	(lb)	(kg)	(lb)	(kg)	(lb)	(kg)
A-1	SEE LOAD RATINGS ON CRANE							
A-2	DO NOT USE		SEE LOAD RATINGS ON CRANE					
A-3	DO NOT USE		SEE LOAD RATINGS ON CRANE					
A-4	DO NOT USE		DO NOT USE					

Boom Position	Leg Pos. 1		Leg Pos. 2		Leg Pos. 3		Leg Pos. 4	
	(lb)	(kg)	(lb)	(kg)	(lb)	(kg)	(lb)	(kg)
B-1	SEE LOAD RATINGS ON CRANE							
B-2	DO NOT USE		SEE LOAD RATINGS ON CRANE					
B-3	DO NOT USE		SEE LOAD RATINGS ON CRANE					
B-4	DO NOT USE		DO NOT USE					

Dimensions are for reference only and subject to change without notice.

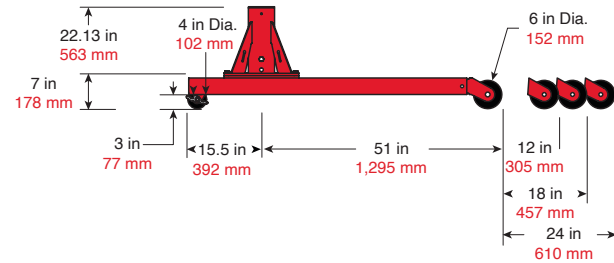

Commander® AL 5AT2 on Wheel Base

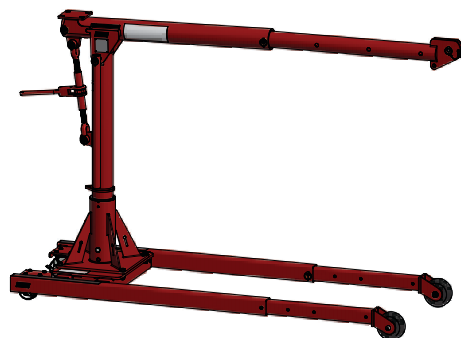

IMPORTANT:
Crane DOES NOT rotate when assembled in 5BR20 wheel base.

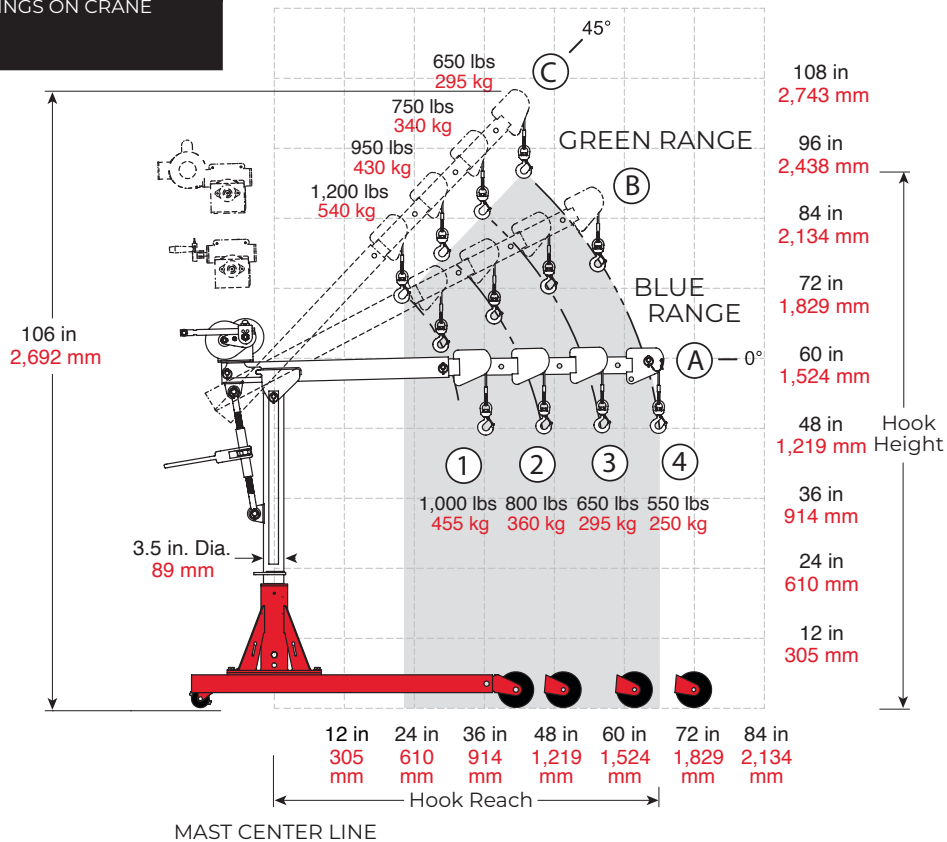

COMMANDER SERIES

AT A GLANCE

MODEL	Crane Weight	Max Capacity	Reach	MAXIMUM HOOK			FINISHES				
				Height (Above Floor)	Lift Distance* (Below Floor)	Long Lift** (Below Floor)	Powder Coat (Red)	Galv	304 SS	316 SS	Epoxy Paint (Gray)
Commander AL Series 5AT1	53 lbs 24 kg	650 lbs 300 kg	66 in 1,676 mm	85 in 2,159 mm	77 ft 23.4 m	287 ft 87.4 m	•				•
Commander AL Series 5AT2	81 lbs 38 kg	1200 lbs 540 kg	66 in 1,676 mm	85 in 2,159 mm	77 ft 23.4 m	287 ft 87.4 m	•				•
Commander 500 Series 5PT5	86 lbs 39 kg	650 lbs 300 kg	66 in 1,676 mm	85 in 2,159 mm	77 ft 23.4 m	287 ft 87.4 m	•	•	•	•	•
Commander 1000 Series 5PT10	122 lbs 55 kg	1200 lbs 540 kg	66 in 1,676 mm	85 in 2,159 mm	77 ft 23.4 m	287 ft 87.4 m	•	•	•	•	•
Commander 2000 Series 5PT20	213 lbs 97 kg	2000 lbs 905 kg	82 in 2,082 mm	97 in 2,463 mm	60 ft 18.2 m	435 ft 132.5 m	•	•	•	•	•

*Maximum lift distance may vary based on winch selection. See crane Performance Rating table.

**Contact factory for long lift ratings requirements. Max capacity may vary depending on wire rope diameters.



CRANE

OPTIONS & ACCESSORIES



Base Anchor Kit	
Model	Description
AN50A-5	(4) Hilti® zinc-plated steel fasteners 1/2" X 5.50" STL (5PA5, 5PF5, and 5PT5 cranes)
AN50A-5S	(4) Hilti® 304 stainless-steel fasteners 1/2" X 5.50" SST304 (5PA5, 5PF5, and 5PT5 cranes)
AN50A-5S316	(4) Hilti® 316 stainless-steel fasteners 1/2" X 5.50" SST316 (5PA5, 5PF5, and 5PT5 cranes)
AN62A-6	(4) Hilti® zinc-plated steel fasteners 5/8" X 6.00" STL (5PA10, 5PT10, 5PT20, 5AT1, 5AT2, and 5FT20 cranes)
AN62A-6S	(4) Hilti® 304 stainless-steel fasteners 5/8" X 6.00" SST304 (5PA10, 5PT10, 5PT20, 5AT1, 5AT2, and 5FT20 cranes)
AN62A-6S316	(4) Hilti® 316 stainless-steel fasteners 5/8" X 6.00" SST316 (5PA10, 5PT10, 5PT20, 5AT1, 5AT2, and 5FT20 cranes)

Rotational Lock	
Model	Description
5P5LCK	For pedestal, wall, and flush-mount bases, 316 stainless steel—available for use 5PA5, 5PF5, and 5PT5

Cable Spooler	
Model	Description
RW50	316 stainless-steel reel winds up wire rope when detached from crane

Wire Rope Keeper	
Model	Description
RK19-25S	304 Stainless-steel bracket holds free end of the wire rope when detached from the crane
RK19-25S316	316 Stainless-steel bracket holds free end of the wire rope when detached from the crane

Roller Ball Bearing for 5PT10 & 5AT1 Cranes	
Model	Description
5PT10BRG	Red electrostatic, powder-coat paint finish
5PT10BRG-S	304 stainless-steel, electro-polished finish for added protection against corrosion
5PT10BRG-S316	Stainless-steel, electro-polished finish for maximum protection against corrosion
5PT10BRG-SS	304 stainless steel, for use with stainless-steel base only
5PT10BRG-SS316	316 stainless steel, for use with stainless-steel base only

Roller Ball Bearing for 5PT20 & 5AT2 Cranes	
Model	Description
5PT20BRG	Red electrostatic, powder-coat paint finish
5PT20BRG-S	304 stainless-steel, electro-polished finish for added protection against corrosion
5PT20BRG-S316	Stainless-steel, electro-polished finish for maximum protection against corrosion
5PT20BRG-SS	304 stainless steel, for use with stainless-steel base only
5PT20BRG-SS316	316 stainless steel, for use with stainless-steel base only

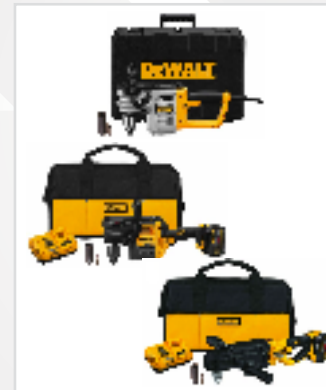
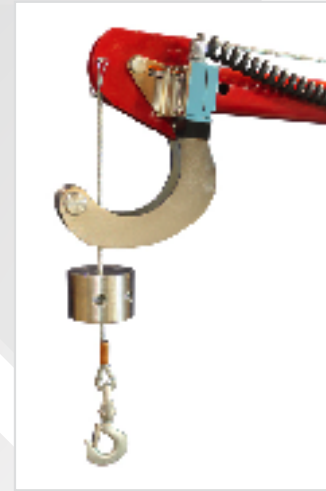

Limit Switch Kits	
Model	Description
NOTE: Limit switch winch option requires purchase of Limit Switch and Headache Ball (sold separately)	
5PT10LS-EL	Limit switch kit for 5AT1 cranes
5PT20LS-EL	Limit switch kit for 5AT2 cranes

Drill Drive Kit	
Model	Description
ED330-DW11	120 VAC, 11-amp, 330 rpm drill motor to power drive the hand winch. Only available for cranes configured with the M2 winch option. Includes 1-1/8" hex drive socket
ED300-DW06	Cordless drill kit, 60 V brushless motor, 300 rpm drill motor to power drive the M2 hand winch option. Includes 1-1/8" hex drive socket
ED400-DW09	Heavy-duty cordless drill kit, 60 V brushless motor, 400 rpm drill motor to power drive the M2 hand winch option. Includes 1-1/8" hex drive socket

Headache Ball	
Model	Description
HB10-12-25	Red enamel painted 10 lb fits 1/8" to 1/4" rope
HB10-25-38	Red enamel painted 10 lb fits 1/4" to 3/8" rope
HB10S-12-25	Stainless-steel 10 lb fits 1/8" to 1/4" rope
HB10S-25-38	Stainless-steel 10 lb fits 1/4" to 3/8" rope
HB10S-44-50	Stainless-steel 10 lb fits 7/16" to 1/2" rope

Base Extension	
Model	Description
5BE5-15	Available on 5PF5, 5PT5, 5PT10, 5PT20, 5AT1 and 5AT2 with powder-coat, galvanized, 304 & 316 stainless-steel, and epoxy finishes
5BE10-15	
5BE20-15	





Stratalign Limited

6 Harbour Ridge Drive
Wiri, Auckland
2104
New Zealand

09 263 7725
sales@stratalign.co.nz
www.stratalign.co.nz