

## TECHNICAL DATA SHEET

RWM HEAVY-DUTY ELECTRIC CHAIN HOIST - DUAL SPEED -  
2500KG CAPACITY

MODEL: WR-2500-2/S



09 263 7725 (Auckland)  
03 222 2836 (Christchurch)



sales@stratalign.co.nz  
www.stratalign.co.nz



6 Harbour Ridge Drive,  
Wiri, Auckland, 2104

# TECHNICAL DATA SHEET

**RWM HEAVY-DUTY ELECTRIC CHAIN HOIST - DUAL SPEED -  
2500KG CAPACITY**

**MODEL: WR-2500-2/S**

## DESCRIPTION

RWM hoists can be considered the Ferrari of hoist brands, and not just because they are engineered and manufactured in Italy by an in-house team.

RWM prides itself on engineering excellence: every hoist is hand-crafted from the highest quality materials. As a result, RWM hoists can safely operate in temperatures as low as -20°C and as high as +50°C – an operating range up to 40% larger than other common hoist brands. This makes RWM the go-to hoist for material handling tasks in harsher environments.

RWM hoists are also the ideal option for demanding industrial applications where uptime is critical. While many hoists have a duty cycle of 40%, RWM hoists have duty cycles as high as 15+40%.

RWM hoists and the more common economy hoists are different tools designed for various uses. Just as you wouldn't invest in a Ferrari as a run-around vehicle, you wouldn't invest in a RWM hoist if you don't require the additional quality and reliability that comes with a hand-built, European-engineered masterpiece.

Choose RWM as your go-to hoist for more challenging and demanding situations where quality and durability is paramount.

## FEATURES

- ☒ RWM Electric Chain Hoists are manufactured for Stratalign by RWM, Italy who are ISO 9001:2015 Certified.
- ☒ The Hoists are built in compliance with European regulations:
  - Machinery Directive (DM) 2006/42/CE
  - Low Voltage Directive (DBT) 2014/35/UE
  - Electromagnetic Compatibility Directive (EMC) 2014/30/UE
- ☒ Design Verified by a NZ registered Chartered Professional Engineer.
- ☒ Cylindrical three-phase self-braking motor with an electromagnet, all with class F insulation.
- ☒ The motor brake system is 103V electromechanical spring type.
- ☒ Hoist is IP54 rated
- ☒ The load limiter clutch is a device that limits the maximum travel both upward and downward and acts as a limiter for overloads.
- ☒ The epicyclical type gearbox is lubricated with permanent grease. It is built in high resistance steel and subjected to heat treatments, thus guaranteeing a long life. With the recommended lubricants the hoist is able to operate in environments with temperatures between -20 ° C and + 50 ° C.
- ☒ The electrical panels are produced according to the CEI-EN 60204 standard with the traditional wiring system.
- ☒ The 24V low voltage transformer allows the hoist to carry out a high number of operations equal to 240 starts / hour.



# TECHNICAL DATA SHEET

**RWM HEAVY-DUTY ELECTRIC CHAIN HOIST - DUAL SPEED - 2500KG CAPACITY**

**MODEL: WR-2500-2/S**

## SPECIFICATIONS

SPECIFICATIONS	
<b>Operating Voltage</b>	400V / 50Hz / 3Ph
<b>Load Chain</b>	Load chain according to EN 818-7-DAT/DT
<b>Pendant Control Cable</b>	5 metre
<b>Power Cable</b>	≈ 4.5 metre without plug
<b>Hoist Protection</b>	IP 54
<b>Classification</b>	M5/2m (ISO/FEM)
<b>Duty cycle / Starts per hour</b>	15+40% / 240
<b>Insulation Class</b>	F
<b>Operating Temperature</b>	-20°C - +50°C

PROTECTION	
<b>Control Switch</b>	24V pendant control switch with emergency stop button.
<b>Overload Protection</b>	Load limiter clutch acts as limiter for overloads.
<b>Brake</b>	Electromagnetic spring pressure brake, holds the load in the event of power failure.
<b>Limit Switch</b>	Electro-mechanical upper and lower limit switch.
<b>Thermal Protection</b>	Protected through heat sensor.

MODEL	CAPACITY kg	LIFTING SPEED m/min	LOAD CHAIN Ømm	CHAIN FALLS	POWER OUTPUT kW	NET WEIGHT kg
WR-2500-2/8	2500	2/8	11 x 31	1	0.8 - 3.5	102



# TECHNICAL DATA SHEET

RWM HEAVY-DUTY ELECTRIC CHAIN HOIST - DUAL SPEED - 2500KG CAPACITY

MODEL: WR-2500-2/S

## DIMENSIONS

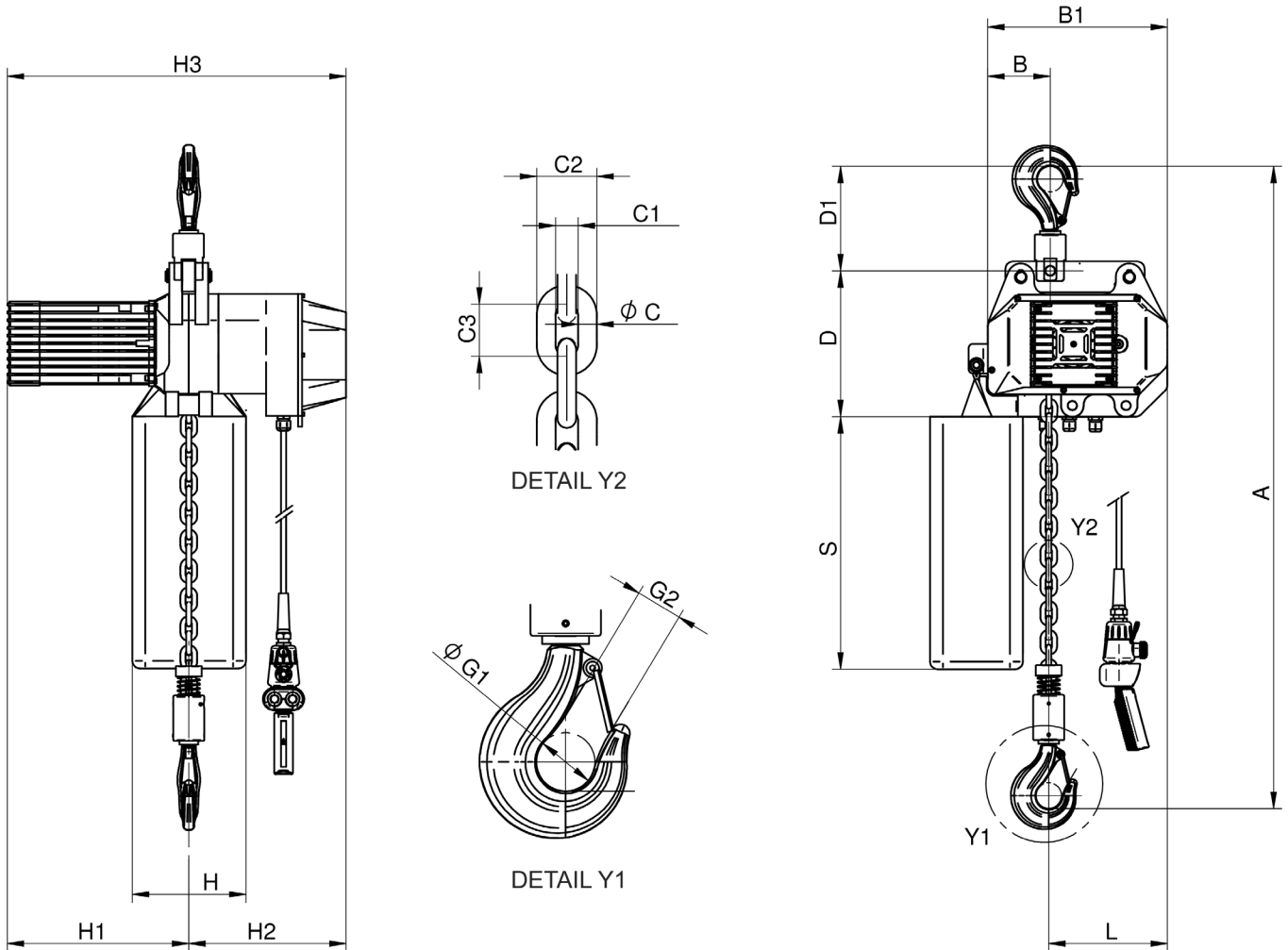

HOIST DIMENSIONS (MM)

MODEL	A	B	B1	$\phi C$	C1	C2	C3	D	D1	$\phi G$	G1	H	H1	H2	H3	L	S
WR-2500-2/8	805	130	350	11	13.2	37.4	31	282	200	50	37	200	350	335	685	230	505

