

TECHNICAL DATA SHEET

RWM ELECTRIC CHAIN HOIST WITH ELECTRIC TROLLEY - DUAL
SPEED - 1000KG CAPACITY

MODEL: W-ET-1000-2/S



09 263 7725 (Auckland)
03 222 2836 (Christchurch)



sales@stratalign.co.nz
www.stratalign.co.nz



6 Harbour Ridge Drive,
Wiri, Auckland, 2104

TECHNICAL DATA SHEET

**RWM ELECTRIC CHAIN HOIST WITH ELECTRIC TROLLEY - DUAL
SPEED - 1000KG CAPACITY**

MODEL: W-ET-1000-2/S

DESCRIPTION

RWM hoists can be considered the Ferrari of hoist brands, and not just because they are engineered and manufactured in Italy by an in-house team.

RWM prides itself on engineering excellence: every hoist is hand-crafted from the highest quality materials. As a result, RWM hoists can safely operate in temperatures as low as -20°C and as high as $+50^{\circ}\text{C}$ – an operating range up to 40% larger than other common hoist brands. This makes RWM the go-to hoist for material handling tasks in harsher environments.

RWM hoists are also the ideal option for demanding industrial applications where uptime is critical, with a duty cycle of 40%.

RWM hoists and the more common economy hoists are different tools designed for various uses. Just as you wouldn't invest in a Ferrari as a run-around vehicle, you wouldn't invest in a RWM hoist if you don't require the additional quality and reliability that comes with a hand-built, European-engineered masterpiece.

Choose RWM as your go-to hoist for more challenging and demanding situations where quality and durability is paramount.

FEATURES

- ✔ RWM Electric Chain Hoists are manufactured for Stratalign by RWM, Italy who are ISO 9001:2015 Certified.
- ✔ The Hoists are built in compliance with European regulations:
 - Machinery Directive (DM) 2006/42/CE
 - Low Voltage Directive (DBT) 2014/35/UE
 - Electromagnetic Compatibility Directive (EMC) 2014/30/UE
- ✔ Design Verified by a NZ registered Chartered Professional Engineer.
- ✔ Cylindrical three-phase self-braking motor with an electromagnet, all with class F insulation.
- ✔ The motor brake system is 103V electromechanical spring type.
- ✔ Hoist is IP54 rated
- ✔ The load limiter clutch is a device that limits the maximum travel both upward and downward and acts as a limiter for overloads.
- ✔ The epicyclical type gearbox is lubricated with permanent grease. It is built in high resistance steel and subjected to heat treatments, thus guaranteeing a long life. With the recommended lubricants the hoist is able to operate in environments with temperatures between -20°C and $+50^{\circ}\text{C}$.
- ✔ The electrical panels are produced according to the CEI-EN 60204 standard with the traditional wiring system.
- ✔ The 24V low voltage transformer allows the hoist to carry out a high number of operations equal to 240 starts / hour.



TECHNICAL DATA SHEET

RWM ELECTRIC CHAIN HOIST WITH ELECTRIC TROLLEY - DUAL SPEED - 1000KG CAPACITY

MODEL: W-ET-1000-2/S

SPECIFICATIONS

SPECIFICATIONS	
Operating Voltage	400V / 50Hz / 3Ph
Load Chain	Load chain according to EN 818-7-DAT/DT
Pendant Control Cable	5 metre
Power Cable	≈ 4.5 metre without plug
Hoist Protection	IP 54
Classification	M5/2m (ISO/FEM)
Duty cycle / Starts per hour	40% / 240
Insulation Class	F
Operating Temperature	-20°C - +50°C

PROTECTION	
Control Switch	24V pendant control switch with emergency stop button.
Overload Protection	Load limiter clutch acts as limiter for overloads.
Brake	Electromagnetic spring pressure brake, holds the load in the event of power failure.
Limit Switch	Electro-mechanical upper and lower limit switch.
Thermal Protection	Protected through heat sensor.

ELECTRIC HOIST

MODEL	CAPACITY kg	LIFTING SPEED m/min	LOAD CHAIN Ømm	CHAIN FALLS	POWER OUTPUT kW	NET WEIGHT kg
W-ET-1000-1/4-7/14	1000	1/4	7 x 22	1	0.4 - 1.8	74

ELECTRIC TROLLEY

MODEL	TYPE	CAPACITY kg	TRAVERSING SPEED m/min	DUTY CYCLE %	POWER OUTPUT kW	BEAM WIDTH mm	MIN. RADIUS m	WHEEL DIAMETER mm
W-ET-1000-1/4-7/14	CE2	1000	7/14	40	0.1/0.2	73-160	1	70



TECHNICAL DATA SHEET

RWM ELECTRIC CHAIN HOIST WITH ELECTRIC TROLLEY - DUAL SPEED - 1000KG CAPACITY

MODEL: W-ET-1000-2/S

DIMENSIONS

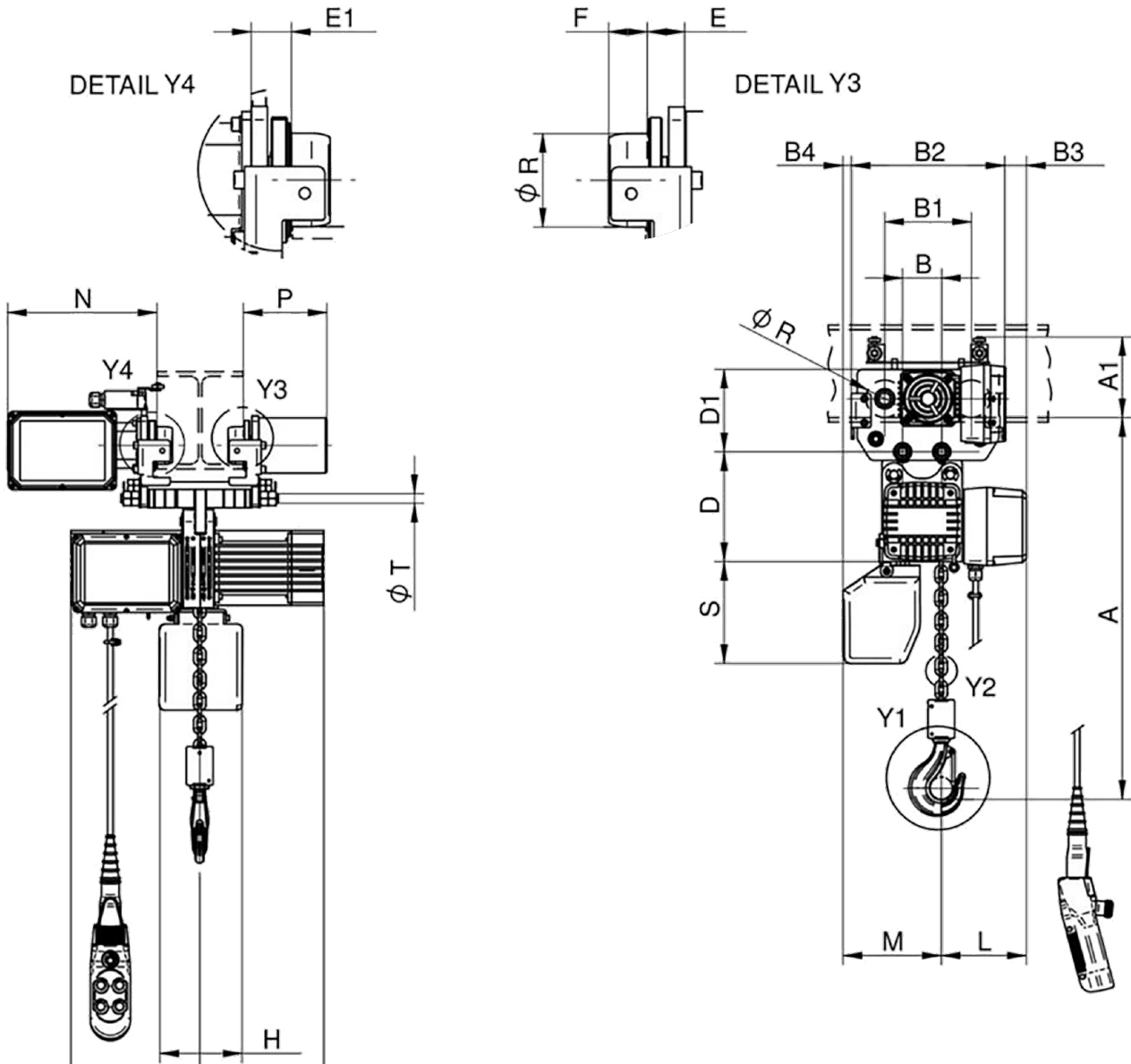

HOIST DIMENSIONS (MM)

MODEL	A	A1	B	B1	B2	B3	B4	D	D1	E	E1	F	H	H1	H2	H3	L	M	N	P	ØR	S	ØT
W-ET-1000-1/4-7/14	470	148	73	162	287	40	15	205	155	28	30	29	190	270	233	503	160	182	280	156	70	280	18



09 263 7725 (Auckland)
03 222 2836 (Christchurch)



sales@stratalign.co.nz
www.stratalign.co.nz



6 Harbour Ridge Drive,
Wiri, Auckland, 2104

TECHNICAL DATA SHEET

RWM ELECTRIC CHAIN HOIST WITH ELECTRIC TROLLEY - DUAL
SPEED - 1000KG CAPACITY

MODEL: W-ET-1000-2/S

DIMENSIONS

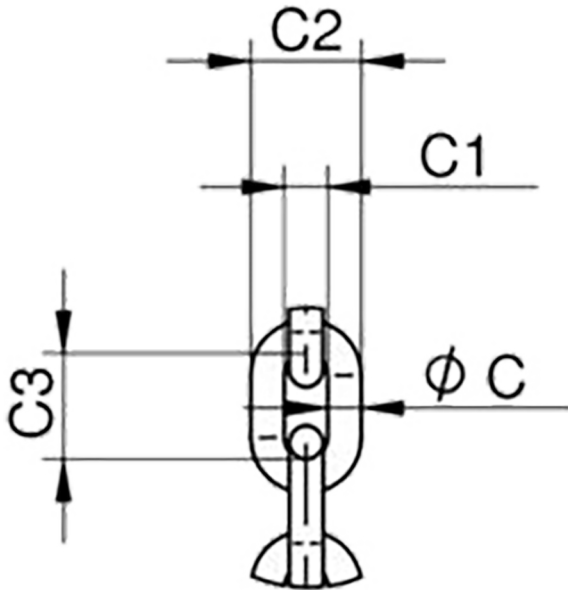

DETAIL Y2

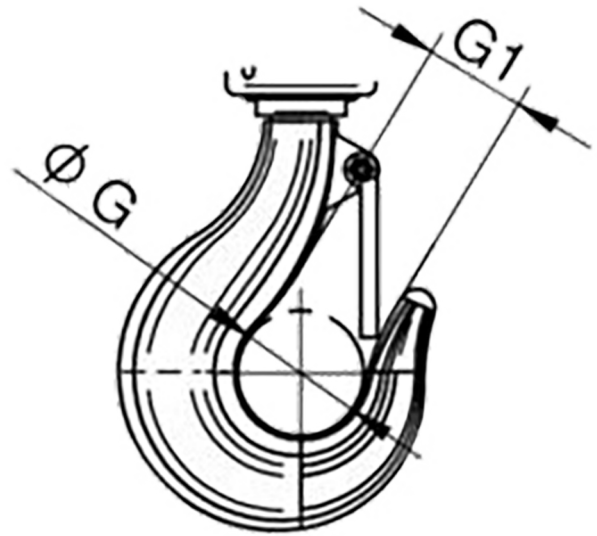

DETAIL Y1

HOIST DIMENSIONS (MM)						
MODEL	ØC	C1	C2	C3	ØG	G1
W-ET-1000-1/4-7/14	7	8.4	23.6	22	43	32

